

Math 096 - Final Exam

May 17, 2017

Name key
Score _____

Show all work. Supply explanations when necessary. Partial credit will be awarded for correct work.

1. (2 points) An angle measures 230° . What kind of angle is it? Circle your choice.

straight right acute obtuse reflex

2. (2 points) An angle measures 180° . What kind of angle is it? Circle your choice.

straight right acute obtuse reflex

3. (2 points) How many congruent sides does a scalene triangle have? 0 (None)

4. (2 points) What is the name of a polygon with 9 sides? Nonagon

5. (3 points) What does CPCTC stand for?

CORRESPONDING PARTS OF CONGRUENT TRIANGLES ARE CONGRUENT.

6. (3 points) Explain why you cannot construct a triangle with sides of lengths 8 in, 3 in, and 4 in.

THE SUM OF LENGTHS OF ANY TWO SIDES MUST EXCEED THE 3RD.

$$3 + 4 \text{ IS NOT GREATER THAN } 8.$$

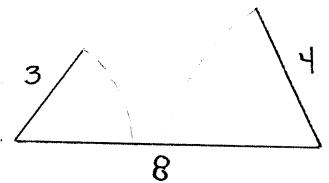

7. (5 points) Find the measure of each interior angle of a regular heptagon.

$$\frac{(7-2)(180^\circ)}{7} \approx \textcircled{128.57^\circ}$$

8. (14 points) The parallel lines p and q are cut by transversal r . The measure of one of the angles is shown below. Find the measures of the seven (7) other angles and, for each one, briefly tell how you know.

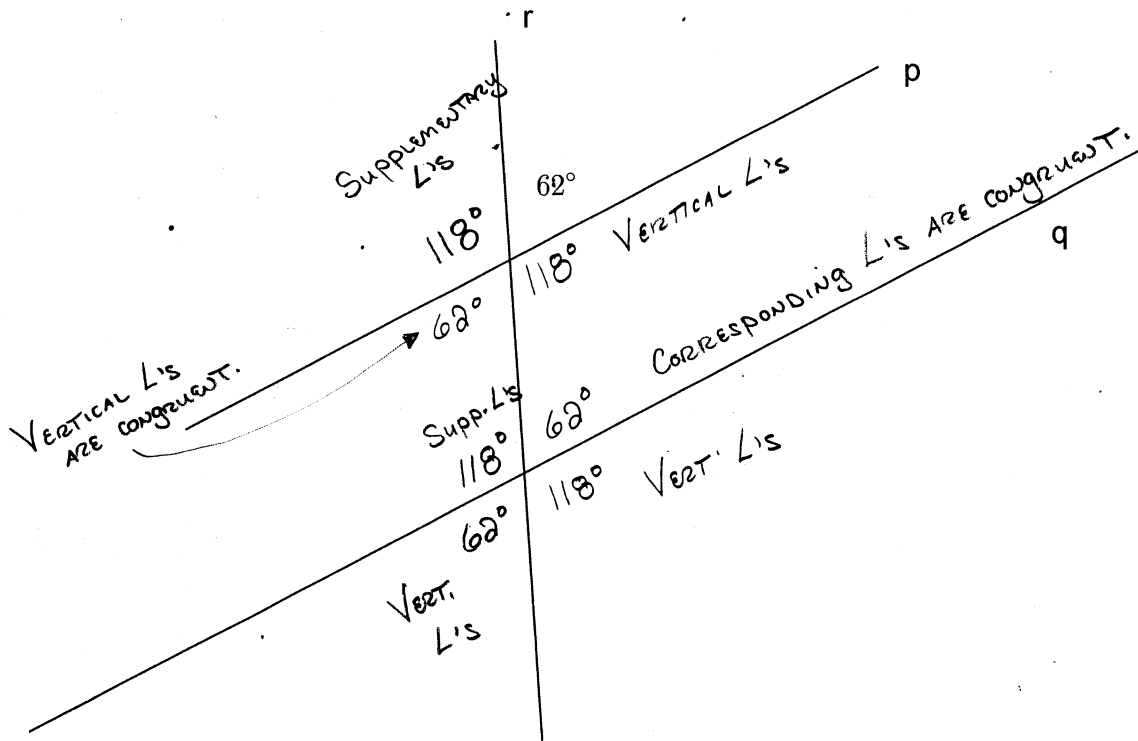

9. (5 points) Suppose the ray \overrightarrow{AD} bisects $\angle BAC$. Determine $m(\angle BAC)$ if $m(\angle DAC) = 28^\circ$.

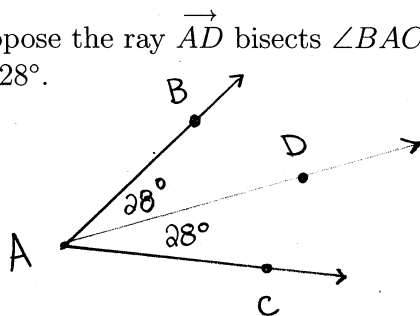

$$28^\circ + 28^\circ = 56^\circ$$

$$m(\angle BAC) = 56^\circ$$

10. (3 points) Sketch a concave quadrilateral. (Use a straight-edge.)

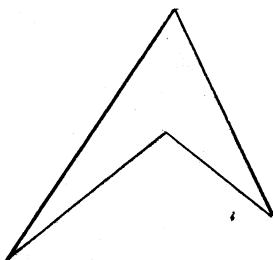

11. (6 points) Use a straightedge to sketch an obtuse angle. Then bisect the angle using only compass and straightedge. Show all your steps.

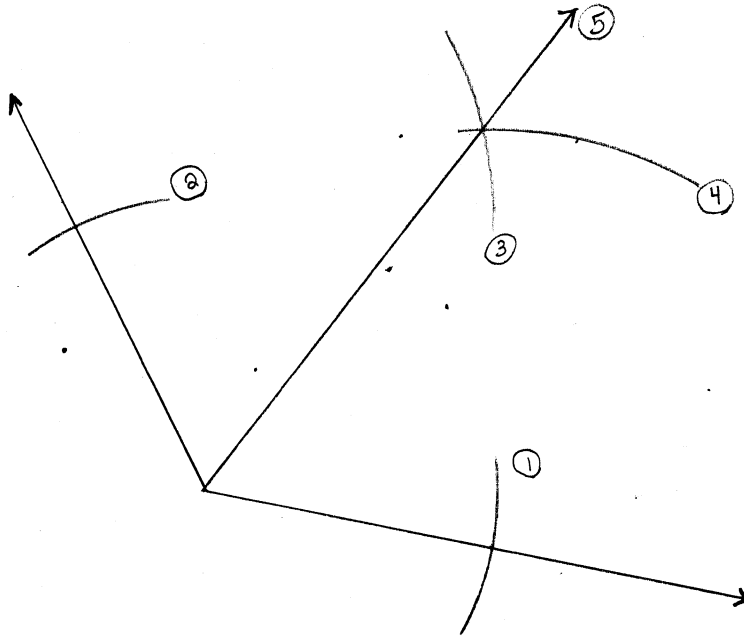

12. (6 points) Two angles are supplementary. One of the angles has degree measure x and the other has degree measure $4x + 35^\circ$. Find x .

$$x + (4x + 35^\circ) = 180^\circ$$

$$5x + 35^\circ = 180^\circ$$

$$5x = 145^\circ$$

$$x = 29^\circ$$

13. (3 points) What is the sum of the measures of the exterior angles a convex polygon with 49 sides?

Sum is 360° For Any convex polygon.

14. (4 points) Determine whether the lines p and q are parallel. Explain how you know.

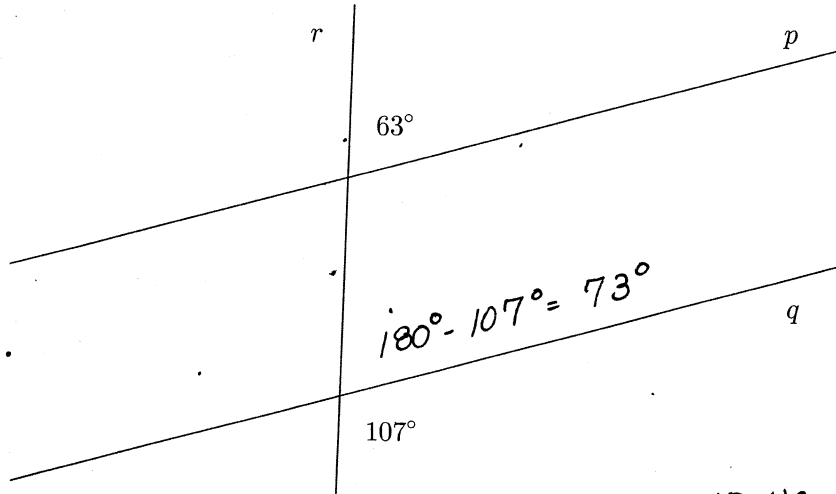

Corresponding \angle s
ARE NOT CONGRUENT

\Rightarrow LINES ARE
NOT PARALLEL.

15. (5 points) In the figure below, point C lies on \overleftrightarrow{AB} . Which of the following words describe the relationship between $\angle 1$ and $\angle 2$. Circle all that apply.

vertical complementary adjacent congruent supplementary

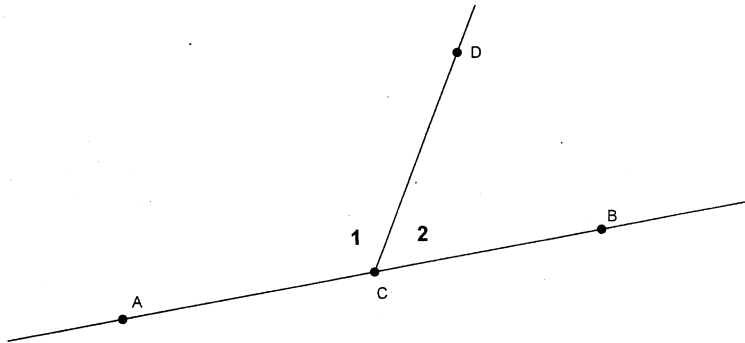

16. (4 points) Sketch an acute angle. Then use your protractor to find the measure of the angle.

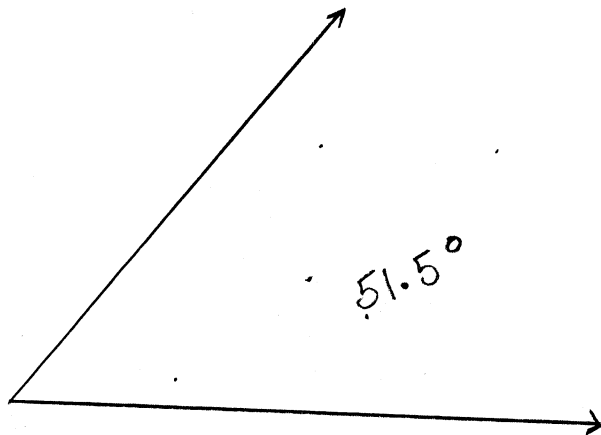

17. (6 points) Find the value of x so that the lines m and n are parallel. Show your work.

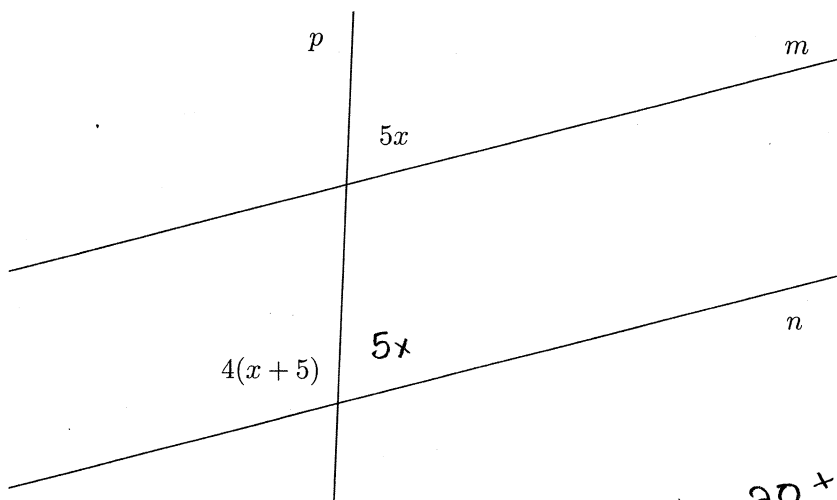

$$4x + 20 + 5x = 180$$

$$9x = 160$$

$$x = 17.\bar{7}^\circ$$

18. (8 points) In the following figure, the parallel lines m and n are being cut by transversal p .

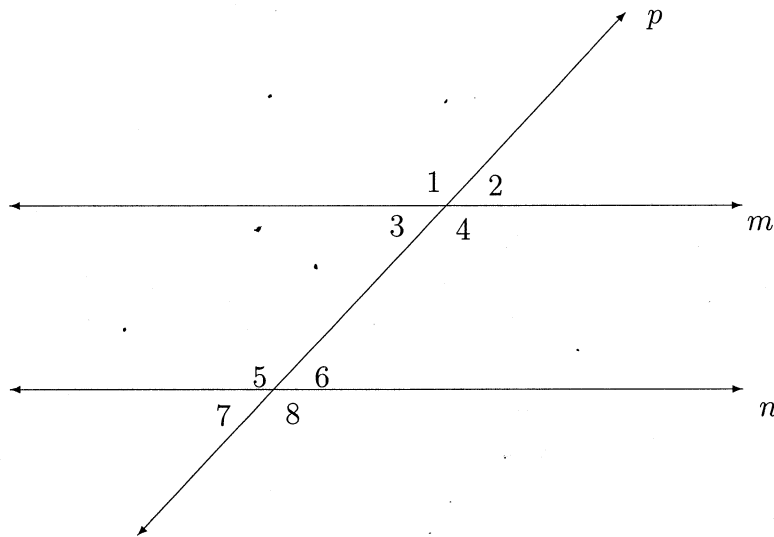

- (a) Name a pair of corresponding angles.

$\angle 1$ & $\angle 5$

- (b) Find $m(\angle 1)$ if $m(\angle 7) = 45^\circ$.

$$180^\circ - 45^\circ = 135^\circ$$

- (c) Find $m(\angle 5)$ if $m(\angle 3) = 36^\circ$.

$$180^\circ - 36^\circ = 144^\circ$$

- (d) Name a pair of alternate exterior angles.

$\angle 1$ & $\angle 8$

19. (8 points) Find the measure of $\angle A$. Briefly explain your reasoning.

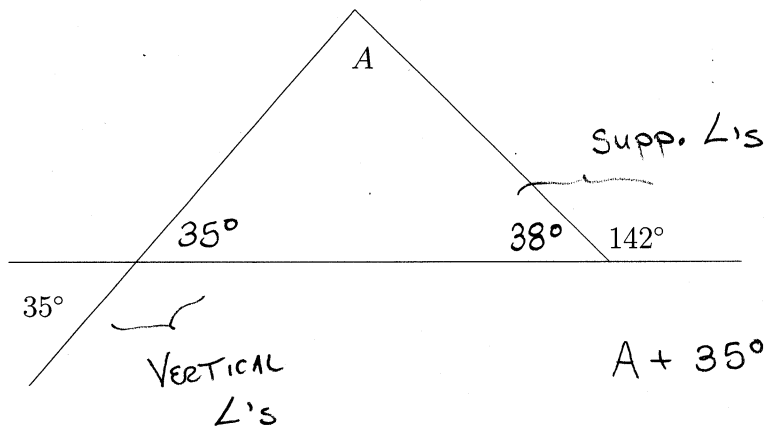

$$A + 35^\circ + 38^\circ = 180^\circ$$

$$\Rightarrow A = 107^\circ$$

20. (6 points) In the figure below, suppose $\overline{AD} \cong \overline{MR}$, $\overline{SD} \cong \overline{RP}$, and $\angle D \cong \angle R$.

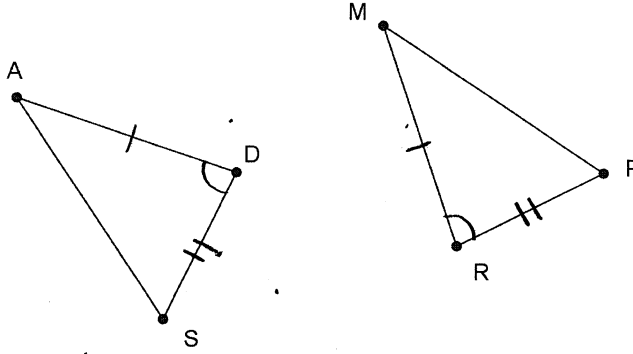

(a) What congruence property justifies that the triangles are congruent?

SAS

(b) Write a correctly ordered congruence relationship.

$$\triangle ADS \cong \triangle MRP$$

21. (6 points) The figure shown below is a trapezoid with $\overline{HL} \parallel \overline{JK}$. Suppose $m(\angle H) = 101^\circ$ and $m(\angle K) = 44^\circ$. Find the measures of $\angle J$ and $\angle L$.

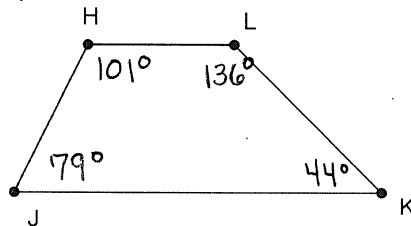

$$m(\angle J) = 180^\circ - 101^\circ = 79^\circ$$

$$m(\angle L) = 180^\circ - 44^\circ = 136^\circ$$

22. (9 points) $\triangle ABC$ is a right triangle with the right angle at B .

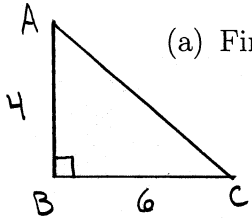

(a) Find AC if $AB = 4$ in and $BC = 6$ in. Write your answer in decimal form.

$$AC^2 = 4^2 + 6^2 \\ = 16 + 36 = 52$$

$$AC = \sqrt{52} \approx 7.21$$

7.21 in

(b) Find the perimeter of $\triangle ABC$. Include units on your answer.

$$4 \text{ in} + 6 \text{ in} + 7.21 \text{ in} = 17.21 \text{ in}$$

(c) Find the area of $\triangle ABC$. Include units on your answer.

$$\frac{1}{2}(4)(6) = 12 \text{ in}^2$$

23. (6 points) A parallelogram is a quadrilateral with two pairs of parallel sides. State two properties of parallelograms.

① Opposite \angle 's ARE CONGRUENT.

② Opposite SIDES ARE CONGRUENT.

24. (9 points) A circle has diameter 3 m. For each problem below, include units with your answer.

(a) Find the radius of the circle.

$$r = \frac{d}{2} \Rightarrow r = 1.5 \text{ m}$$

(b) Find the circumference of the circle.

$$C = 2\pi r \quad 2\pi(1.5) = 3\pi$$

$$\approx 9.42 \text{ m}$$

(c) Find the area of the circle.

$$A = \pi r^2$$

$$\pi(1.5)^2$$

$$= 2.25\pi \approx$$

$$7.07 \text{ m}^2$$

25. (8 points) A base angle of an isosceles triangle has measure 45° , and the legs (not the base) have length 10 cm. Roughly sketch the triangle. Then find the measures of the other angles and the length of the base.

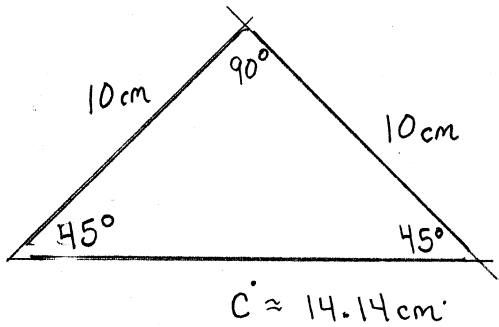

$$\frac{\sqrt{a}}{a} \cdot C = 10$$

$$\Rightarrow C = \frac{20}{\sqrt{2}} \approx 14.14 \text{ cm}$$

26. (3 points) Solve for t : $\frac{3}{t} = \frac{5}{12}$.

$$5t = 36$$

$$\Rightarrow t = 7.2$$

27. (8 points) Suppose $\triangle ABC \sim \triangle DBE$. Find EB if $AC = 10$, $DE = 8$, and $CB = 8$.

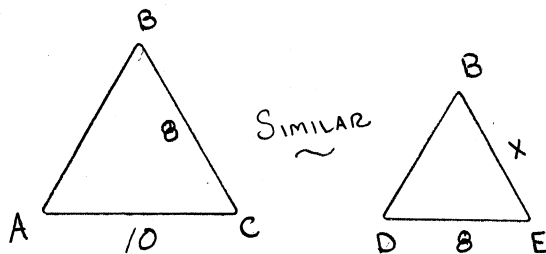

$$\frac{10}{8} = \frac{8}{x}$$

$$\Rightarrow 10x = 64$$

$$x = 6.4$$

28. (4 points) Suppose you are given the two triangles, $\triangle RST$ and $\triangle UVW$. Also suppose that $\angle T \cong \angle W$ and $\frac{TR}{WU} = \frac{TS}{WV}$. What property justifies that $\triangle RST \sim \triangle UVW$?

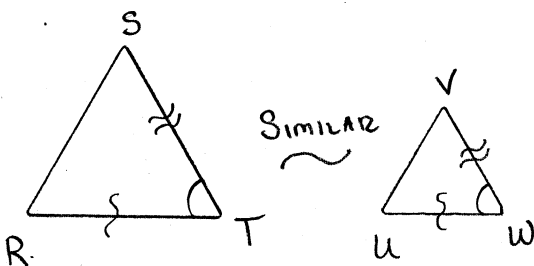

SAS \sim